

















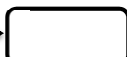





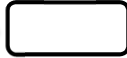









**DAFTAR FLOWCHART KEPALA BIDANG SUMBER DAYA AIR
DINAS PEKERJAAN UMUM DAN PENATAAN RUANG KABUPATEN MEMPAWAH**

NO	KEGIATAN						MUTU BAKU			KET
		KABID	KADIS	KASI	SURVEYOR	PULAHTA	KELENGKAPAN	WAKTU	OUTPUT	
1	2	3	4	5	6	7	8	9	10	11
1	Kepala Bidang Sumber Air berdasarkan DPA memerintahkan Kepada Kasi Pengembangan Daerah Rawa dan Pantai serta kasi Irigasi dan Air Baku menghimpun data berkaitan terhadap kedua seksi tersebut						Pengarahan	20 Menit	Disposisi untuk penyiapan data	
2	Menyiapkan data Pengembangan Daerah Rawa dan Pantai serta data Irigasi dan Air Baku						Komputer	2 Jam	Data DR dan DI	
3	Menjadwalkan serta memberi arahan kepada Kepala Seksi untuk melaksanakan Survey pendahuluan terhadap Seksi Pengembangan daerah Rawa dan Pantai serta Seksi Irigasi dan Air Baku						Komputer Kendaraan Bermotor	2 Jam	Jadwal dan Pengarahan	
4	Meminta Petunjuk serta arahan dari Pimpinan tentang kebijakan yang akan diambil						-	30 Menit	Arahan dari Kadis	
5	Memerintahkan kepada Staf untuk menyiapkan keperluan administrasi termasuk Surat Tugas untuk Survey Pendahuluan						Komputer Kertas Alat Tulis	1 Jam	Surat Tugas	
6	Memberikan arahan sebelum melakukan survey pendahuluan						Data	1 Jam	Arahan Kabid	
7	Mengumpulkan data Primer dan Sekunder						Komputer Kendaraan Bermotor	25 Hari	Data	
8	Mengolah data berdasarkan hasil survey pendahuluan						Komputer Alat Tulis	30 Hari	Draft EE	
9	Melakukan analisa dan evaluasi data serta kompilasi dengan hasil survey pendahuluan menentukan datail dasain yang sesuai dengan kedua seksi tersebut						Komputer Alat Tulis	30 Hari	EE dan DD	
10	Meminta petunjuk atasan tentang hasil analisa detail desain hasil survey untuk kedua Seksi tersebut						-	1 Jam	EE dan DD	
11	Menyusun rencana dokumen hasil study kelayakan						Komputer ATK	5 Hari	EE dan DD	
12	Mengarsipkan dokumen hasil survey pendahuluan						Kertas, Map	2 Hari	EE dan DD	